

North America Phase Converters & Electrical Supply

OPERATION AND
INSTALLATION
MANUAL

ROTARY
PHASE CONVERTERS

Models PL, UL & CP
(Manual PL-Delta)

240 VOLTS – Delta

WARNING: To reduce the risk of injury, the user must read and understand the operator's manual before using this product.

Table of Contents

Section 1: Introduction and Installation Notes

Section 2: Installation

2.1 Typical Line Diagram

2.2 Branch Circuit (Circuit Breaker & Fuse) and Wire Sizing

2.3 Control Panel Connection

2.4 Idler Generator Connection

2.5 Switch Assembly

Section 3: Checking the Converter

3.1 Checking single phase power

Section 4: Operation & Maintenance

4.1 Operation

4.2 Maintenance

Section 5: Trouble Shooting

Section 6: Warranty

Section 1: Introduction and Installation Notes

HIGH VOLTAGE – Risk of Electrical Shock. This equipment is connected to line voltage that can create a potentially hazardous situation.

Your rotary phase converter has been engineered and manufactured to our standards for dependability, ease of operation, and operator safety. When properly cared for, it will give you years of rugged, trouble-free performance.

- Installation of this equipment must comply with all national, state and local electrical codes.
- Installation must be performed by qualified licensed electrician and should have experience working with this line voltage.
- Always make certain power is off before servicing this equipment.
- The input wire gauge must be sized to furnish the single-phase input current (amperage); this wire is larger than the three phase output current to the load.
- Make sure the input voltage is 208-240 before connecting.
- Do not connect control circuits to T3.
- Do not connect a ground or neutral to T3.
- All loads (including transformers) must be turned off/disconnected before starting phase converter.
- Do not bolt idler generator down solid. This can cause diminished generator life.
- Make sure phase converter control panel, generator and equipment are properly grounded.
- Wire recommendations are minimums. Voltage drop is dependent on wire length and gauge. Increase wire one (1) additional size for every fifty (50) feet of wire run.
- Wire recommendation is based on the use of copper wire. If using aluminum wire, use the copper equivalent for current amount.
- Single phase loads must always be energized by lines T1 and T2.

SAVE THIS MANUAL FOR FUTURE REFERENCE

Section 2: Installation

2.1 Typical Line Diagram for Phase Converter

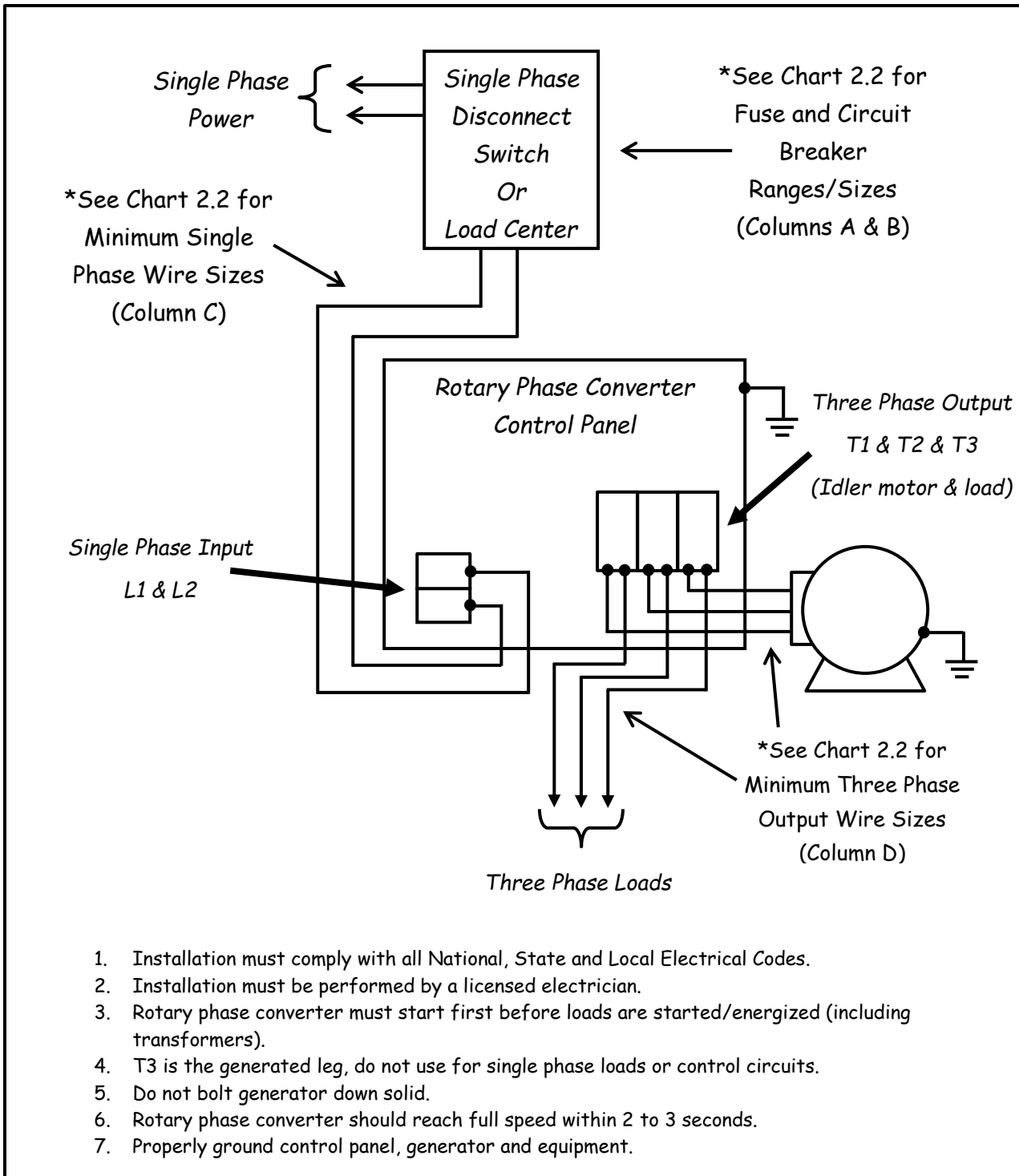

2.2 Branch Circuit and Wire Sizing

Column	A	B	C	D
Phase Converter HP	Minimum Circuit Breaker & Fuse Size	Maximum Circuit Breaker & Fuse Size	Minimum Single Phase Wire Sizes	Minimum Three Phase Wire Sizes
3	10 amps	20 amps	12	12
5	20 amps	30 amps	10	12
7.5	20 amps	40 amps	8	10
10	30 amps	50 amps	6	10
15	40 amps	80 amps	4	8
20	50 amps	100 amps	2	6
25	60 amps	125 amps	1/0	4
30	70 amps	150 amps	2/0	2
40	100 amps	200 amps	4/0	1
50	125 amps	250 amps	250 MCM	2/0
60	150 amps	300 amps	300 MCM	3/0
80	175 amps	325 amps	350 MCM	4/0
100	200 amps	350 amps	350 MCM	4/0

Branch Circuit (Circuit breaker and Fuse) Sizing: Your NAPCES rotary phase converter has a minimum and maximum circuit range/size. Your circuit protection can be sized at the minimum, maximum or anywhere between the two amounts.

To determine your single phase branch circuit required to feed your converter and load:

- Add your total 3 phase loads together and multiply by 1.73. This is the amount of single phase current you will draw at full load. This is the minimum single phase service needed to run your phase converter and loads. However, the National Electric Code (N.E.C.) Article 455 recommends multiplying your total phase loads by 2.5.

Examples:

Total 3 phase load(s) amperage X 1.73 = Single Phase Current Draw

Total 3 phase load(s) amperage X 2.5 = **Minimum** Circuit Protection Size

Wire / Conductor Sizing: Wire sizing is extremely important in order that proper voltage may be maintained during motor start-up. The N.E.C. Article 455.6 governs the wire size of phase converters. Article 455.6 states that the input wire size shall not be less than 125% of the phase converter nameplate input full-load amperes (for variable loads) and/or not less than 250% of the sum of the full-load 3-phase current rating (for variable and fixed loads).

Minimum wire size recommendations are listed in the chart above. These wire recommendations are for wire runs of fifty (50) feet or less. Increase the wire size one (1) size for every additional fifty (50) foot run.

Note – Wire recommendations are for copper wire. If using aluminum wire, use the copper equivalent for current amount.

2.3 Wire Connection

All NAPCES rotary phase converters are equipped with power distribution blocks for wire terminations.

Single phase **input** power connections are labeled **L1 and L2**.

Output idler generator and load power connections are labeled T1, T2 and T3.

T3 is the manufactured leg of power.

Here is an illustration of the wiring connections:

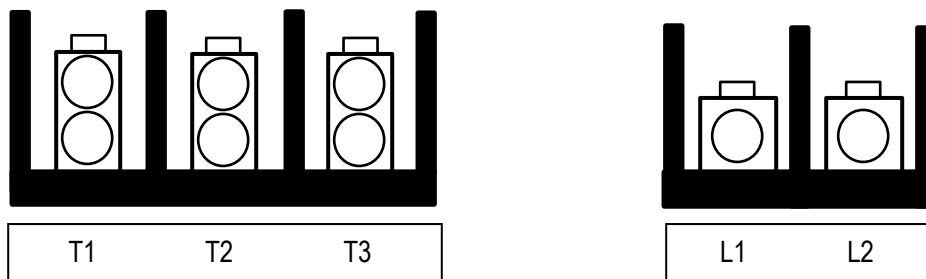

*Front view of power distribution blocks

Recommend Tightening Torque	
10 - 14 AWG	35 Lb.-in
8 AWG	40 Lb.-in
6 - 2/0 AWG	120 Lb.-in
1/0 - 400 MCM	275 Lb.-in

2.4 Idler Generator Connection

For 9 Lead Wire Idler Generators (Motors)

Note: 3 Lead Wire Idler Motor Wiring Instructions Below

CP Important Note – For customers installing CP Models (Control Panels), please follow the wiring diagram for your motor. A diagram should be near, on or in the motor junction box or on the motor name plate.

Connect the idler generator according to the nameplate wiring diagram. Your 9 wire lead connection is most commonly referred to as a delta connection.

Now, connect wire leads 1, 6 & 7 to T1 in the control panel, wire leads 2, 4 & 8 to T2 in the control panel and wire leads 3, 5 & 9 to T3 in the control panel.

Insulate all connection with electrical tape or heat shrink tubing.

Here is a line diagram for reference:

9 Lead Wire Idler Generators

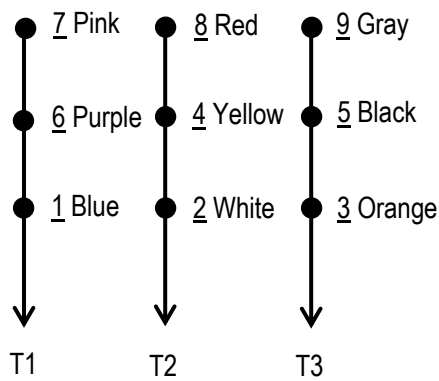

Idler Wire Color Code

1. Blue
2. White
3. Orange
4. Yellow
5. Black
6. Purple
7. Pink
8. Red
9. Gray

For 3 Lead Wire Idler Generators (Motors)

Connect wire leads 1 (Blue Wire) to T1 in the control panel, wire leads 2 (White Wire) to T2 in the control panel and wire leads 3 (Orange Wire) to T3 in the control panel.

3 Lead Wire Idler Generators

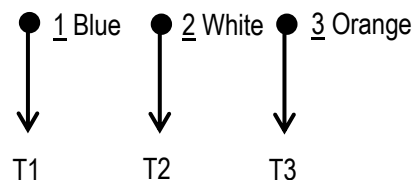

Finally, properly ground idler generator to earth ground.

***Note – this is low voltage. Low voltage is 208 – 240 volts.**

2.5 Switch Assembly

On the front cover of the control panel, press the “red” stop button. While doing this, look at the back side of the panel cover and note on which side the “red” tab pushes forward.

Securely push the terminal blocks into the back of switch. The “red” terminal block matches the “red” tab.

Lastly, slide the tab on top of the terminal blocks to the right (when looking at the back of the switch) to lock the switch terminal blocks into place.

Section 3: Checking the Converter

3.1 Checking Single Phase Line Voltage

Measure the single phase utility input supply voltage between L1 and L2 with a voltmeter and record. It should measure between 220 and 245 on a standard single phase system. **Note** – If your input voltage is too high, you may need to install a buck-boost transformer to decrease the voltage. Please contact NAPCES; we carry a complete line of buck-boost transformers.

Input Voltage L1-L2 _____

3.2 Checking Three Phase Output Voltage

Start the rotary phase converter. Press the “Green” Start push button. A light between the start and stop buttons will illuminate. The phase converter should reach full speed within 2 – 3 seconds. **Note** – If the phase converter does not start in 5 seconds, turn it off.

Measure the output line-to-line voltages at the phase converter and record. This is done by measuring between the three (3) combinations of output terminals. (T1-T2, T1-T3 and T2-T3).

Output Voltages T1-T2 _____, T1-T3 _____, T2-T3 _____

T1-T2's voltage should be the same or within 1-2 volts of L1-L2. T1-T3 and T2-T3 should measure 5 – 15 volts higher than T1-T2 without a load running. Once a load is applied, these voltages will drop down closer together.

Note – Line-to-ground voltages are not relevant. However, T1 and T2 should measure @120 to ground and T3 should measure between 190 and 250 when measuring to ground.

You can now start your loads. **Note** – If a load motor rotates backwards, switch any two (2) connections at the load.

Section 4: Operation & Maintenance

1.1 Operation

1. A NAPCES rotary phase converter may operate continuously with or without a load.
2. DO NOT start the phase converter under load.
3. Wait until phase converter reaches full speed before starting loads.
4. If possible, avoid starting more than one load at the same time.
5. Turn rotary converter off if excessive noise or vibration occurs.

1.2 Maintenance

Your NAPCES converter requires very little maintenance. We recommend periodic lubrication, cleaning and inspection.

Lubrication

All NAPCES rotary phase converters generator bearings are pre-greased by the factory. This initial greasing generally will last the lifetime of the generator; however, a squirt of grease may be needed from time to time.

Recommended grease – Exxon Polyrex EM Bearing Grease**Cleaning and Inspection**

1. Inspect the rotary converter from time to time.
2. Make sure all vents are clear and clean.
3. Clean off dust, dirt and any debris buildup on the generator. This can insulate the generator and cause overheating.
4. Open control panel and inspect power and control components.
5. Check all wires for loose connections, cuts/nicks or damage. Clean, tighten or replace if necessary.

INTENTIONALLY LEFT BLANK

Section 5: Trouble Shooting

Condition	What to look for / Actions
Converter does not start, no noise.	<ul style="list-style-type: none"> -Check (L1-L2) input power source for voltage. -Check circuit breaker or fuses. -Check for loose connection. -Make sure switch terminal blocks are securely attached.
Converter is trying to start but does not.	<ul style="list-style-type: none"> -Check (L1-L2) input power for correct voltage. -Make sure loads are off downstream of converter. -Check generator motor for correct wiring. -Make sure input wire is the correct size. -Check kVA size of transformer, it may be too small.
Converter is vibrating, runs loud or has bearing noise (squealing).	<ul style="list-style-type: none"> -Make sure converter is not bolted down solid. -Check (L1-L2) input power for correct voltage. -Check generator motor for correct wiring. -New converters may need break in period, let run 25 – 50 hours.
Load does not start or run.	<ul style="list-style-type: none"> -Check (L1-L2) input power for correct voltage. -Rotary phase converter may be too small. -Make sure input wire is the correct size. -Check kVA size of transformer, it may be too small. -Measure voltage when load is starting and running, additional capacitors may need to be added. -Check load motor wired for low voltage.
Load motor is running backwards.	<ul style="list-style-type: none"> -Switch any two (2) connections at the load.
Chatter noise from my load relay.	<ul style="list-style-type: none"> -Check (L1-L2) input power for correct voltage. -Check if T3 is connected to motor starting relay (coil).
Output voltage is high.	<ul style="list-style-type: none"> -Check (L1-L2) input power for correct voltage. -Capacitors may need to be removed. Consult NAPCES. -A buck-boost transformer may be needed if single phase input is too high.
Output voltage is low.	<ul style="list-style-type: none"> -Check (L1-L2) input power for correct voltage. -Capacitors may need to be added. Consult NAPCES. -A buck-boost transformer may be needed if single phase input is too low.
Generator feels hot.	<ul style="list-style-type: none"> -Generator will feel warm to the touch. This is a normal condition.

North America Phase Converters & Electrical Supply
Rotary Phase Converter
Limited Lifetime Warranty

North America Phase Converter & Electrical Supply ("NAPCES") warrants that all rotary phase converter control panels (the "Goods") are free from defects in material and workmanship. NAPCES will, at its option, repair or replace any part which, upon examination, inspection and testing by NAPCES or a NAPCES Authorized Service Center, is found to be defective. Warranty work will be scheduled according to the normal work flow and business hours of the service center. Warranty is from the date of purchase and for the original purchaser. All transportation costs under the warranty, including return to the factory, are to be borne and prepaid by the purchaser. Idler generator motor warranties are covered by the manufacturers and subject to their terms and conditions.

Warranty Period: NAPCES parts warranty period for rotary phase converter control panels (the "Goods") is ten (10) years and one (1) year for start capacitors. NAPCES labor warranty period for rotary phase converter control panels (the "Goods") is lifetime. This is a Limited Lifetime Labor Warranty, NAPCES will maintain the control panel and perform repairs caused by normal use, for free, any time during the control panels useful life and does not cover accidents, misuse, abuse, negligence, alterations or repairs by unauthorized personnel.

This warranty is exclusive and is in lieu of any other warranty expressed or implied, including but not limited to any implied warranty or merchantability or fitness for a particular purpose.

Warranty Exclusions: The above warranty does not cover: workmanship of installation, dissatisfaction or damage due to improper installation, vandalism, misuse, accident, excessive wear and tear, unauthorized repair, abnormal use, lack of maintenance, or other(s) not within NAPCES's control. North America Phase Converters & Electrical Supply ("NAPCES") will not be liable, under any circumstances, for consequential or incidental damages, including but not limited to labor costs, lost profits resulting from the use of or inability to use the goods or from the goods being incorporated in or becoming a component or any other product. Without limiting the generality of the foregoing, NAPCES will not be responsible for the labor costs involved in the removal of Goods or the installation of replacement Goods. NAPCES will not accept the return of any Goods without its prior written approval.

A licensed electrician must perform all installations and must comply with all national and local electrical codes. Not all NAPCES rotary phase converters are UL certified. UL is an option and must be specified when ordered. Customer is responsible for meeting and complying with installation codes and inspections.